

THIS DRAWING IS UNPUBLISHED. RELEASED FOR PUBLICATION, 19  
 © COPYRIGHT 19 BY AMP INCORPORATED. ALL INTERNATIONAL RIGHTS RESERVED.

LOC	DIST	P	F	ZONE	LTR	DESCRIPTION	DATE	APPD
AF	50				A	RELEASE PER FASR & 0L10-0161-97	21/APR/97	PF/DS

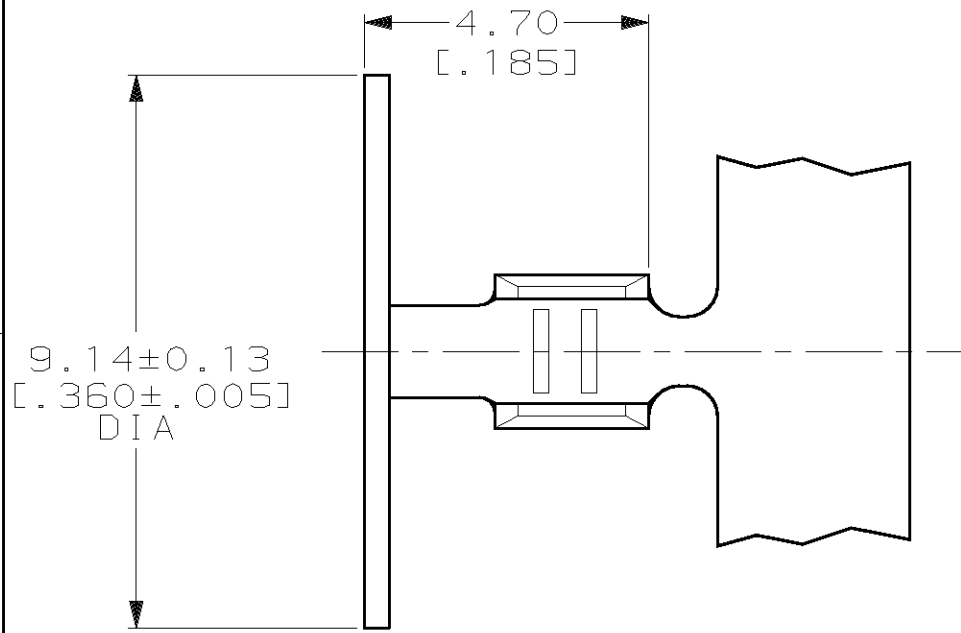

1 CONTINUOUS STRIP ON REEL.

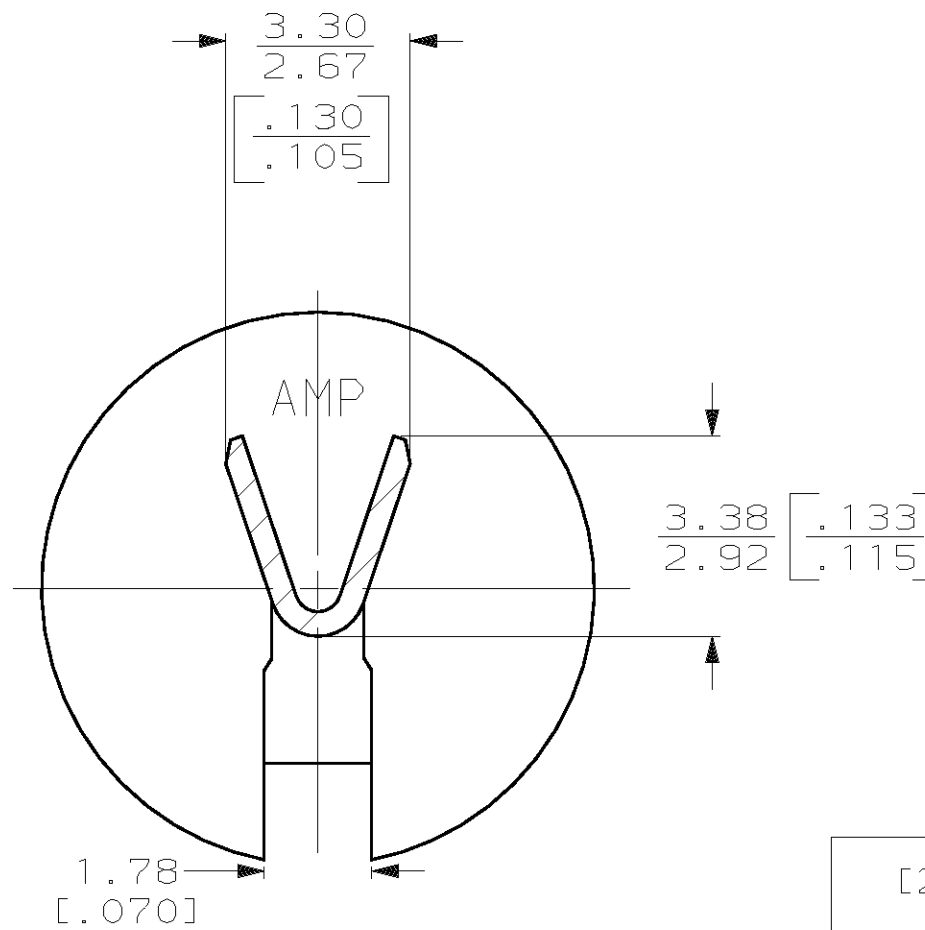
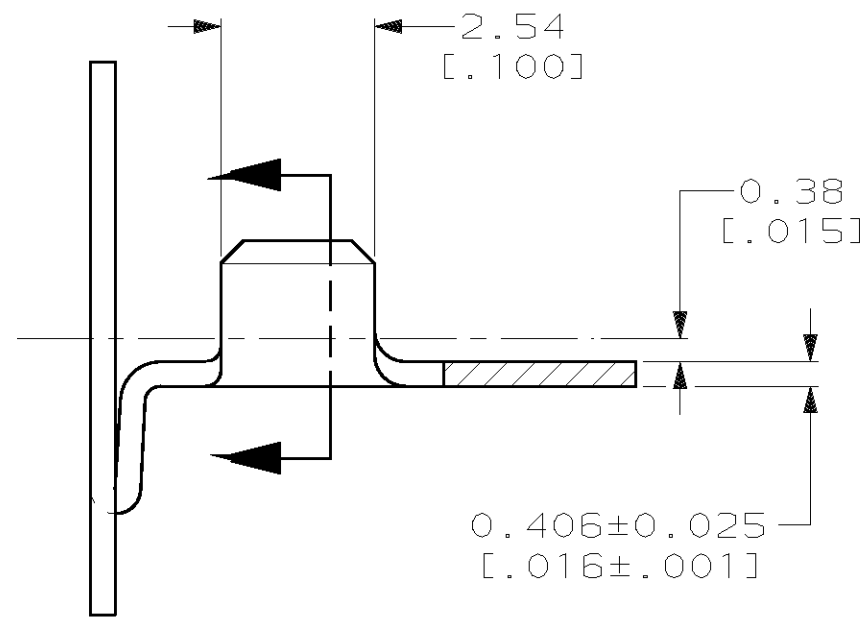

[20-16] AWG	63930-1
WIRE RANGE	PART NO

DO NOT SCALE PRINT. UNLESS SPECIFIED DIMENSIONS IN mm [INCHES] TOLERANCES ON: 2 PLC DEC ± 0.25 [.010] 3 PLC DEC ± - ANGLES ± -	DR 27/AUG/96 PHILLIP M FORTNEY
	CHK 27/AUG/96 JEFF R RUTH
MATERIAL 082 BRASS	APPD 27/AUG/96 DENNIS SCHWENK
	APPD 27/AUG/96 MARK BARNABA
FINISH -	PRODUCT SPEC -
	APPLICATION SPEC -
	WEIGHT -

AMP Incorporated Harrisburg, PA 17105-3608		
NAME CONTACT, BRUSH		
SIZE B	CAGE CODE 00779	DRAWING NO C-63930
SCALE 8:1	SHEET 1 OF 1	

THIS DRAWING IS A CONTROLLED DOCUMENT FOR AMP INCORPORATED. IT IS SUBJECT TO CHANGE AND THE CONTROLLING ENGINEERING ORGANIZATION SHOULD BE CONTACTED FOR THE LATEST REVISION.