

TBL-1608-245-M2 THIN FILM BALUN

1. Feature

- 1-1 2.45GHz Thin Film Balun.
- 1-2 For ISM Band applications like Bluetooth/WLAN.
- 1-3 Lead Free, RoHS compliance

2. Part Number

TBL — 1608 — 245 — M2 — XX

(1) (2) (3) (4) (5)

Where (1) TBL : Thin Film Balun

(2) Size :

4 digits of number —1608 = 1.60x0.8 mm

(3) Center Frequency :

245 = 2.45 GHz

(4) Type

Refer to Table 3-1

(5) XX

Internal Code

3. Ratings

3-1 Specifications

Part Number	TBL-1608-245-M2
Unbalance Port Impedance	50Ω
Balance Port Impedance	100Ω
Nominal Center Frequency	2450MHz
Bandwidth	2400 ~ 2500MHz
Phase Balance	180 ±10°
Amplitude Balance	0 ±1.0dB max
Insertion Loss	1.0 dB Max. at +25°C
VSWR at Unbalance Port in BW	2.0 Max.
Power Capacity	500mW Max.

3-2 Operation Temperature: -40°C to +85°C

3-3 Storage Temperature: +15°C to +35°C

4. Outline Dimension

TopView

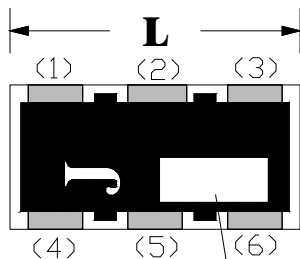

Directional Marking

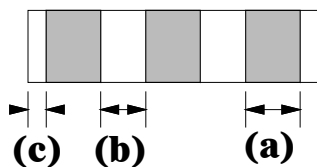

BackView

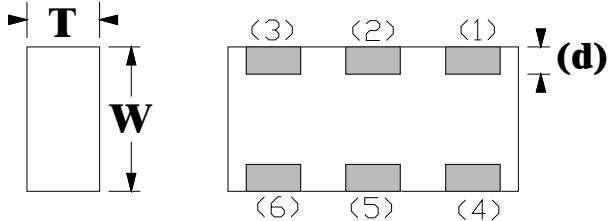

Terminal Configuration

Code	Dimension(mm)	Code	Dimension(mm)
L	1.6±0.1	(a)	0.3±0.1
w	0.8±0.2	(b)	0.25±0.1
T	0.4±0.1	(e)	0.1±0.1
		(d)	0.2±0.1

(1)	GND
(2)	NC
(3)	Unbalance Port
(4)	Balance Port
(5)	NC
(6)	Balance Port

5. Electrical Performance

Insertion Loss and Return Loss

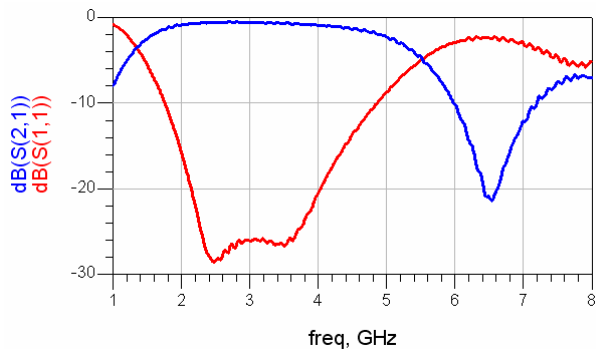

Amplitude Balance

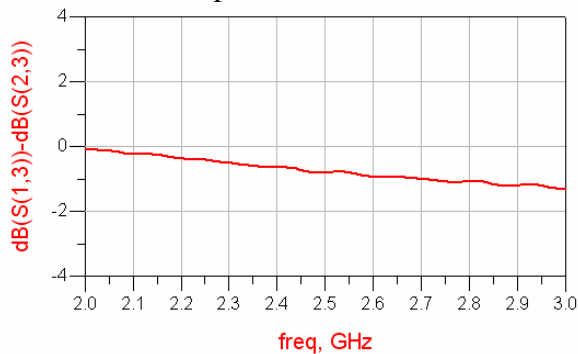

Phase Balance

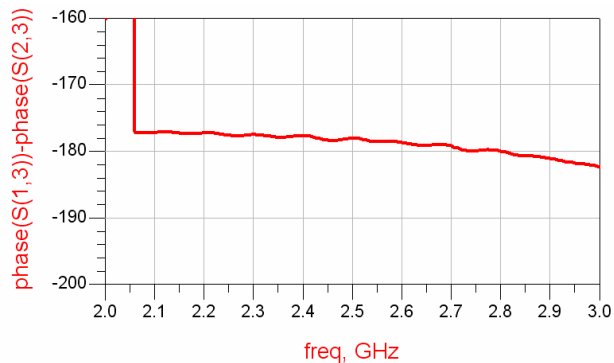

6. Measurement

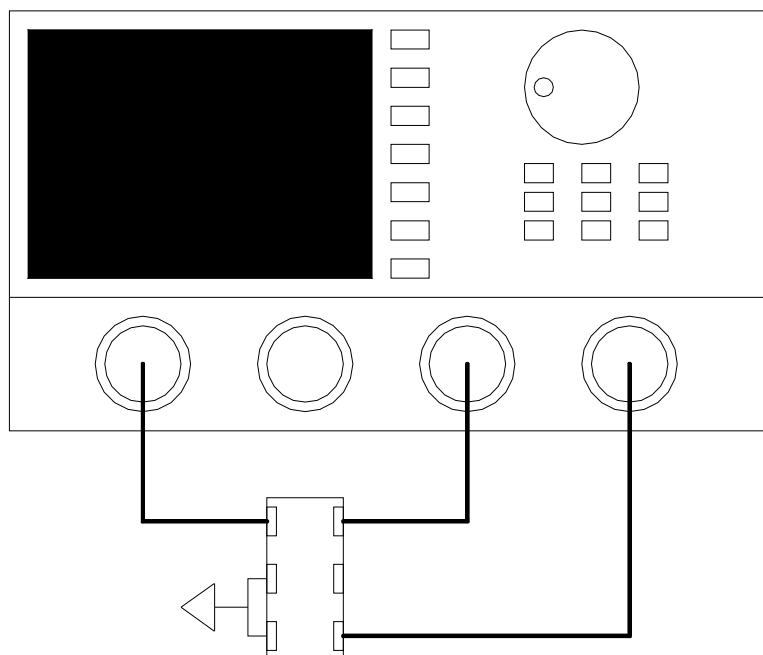

Network analyzer : Agilent PNA N5230A

7. Recommended Land Pattern

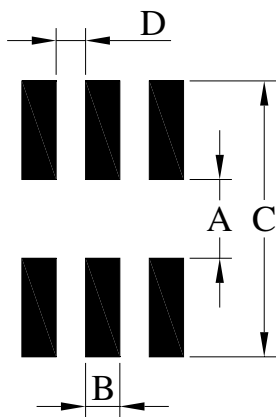

A	0.3
B	0.25
C	1.4
D	0.25

Unit : mm

8. Reliability Test

8-1 Electrical

Item	Specification and Requirement	Test Method
Temperature Characteristics	Satisfy electrical characteristics	Solder the sample on PCB. Exposure at each temperature, -40°C, -20°C, 0°C, +25°C, +50°C, +85°C for 30minutes

8-2 Mechanical

Item	Specification and Requirement	Test Method
Solderability	The Surface of terminal immersed shall be minimum of 95% covered with a new coating of solder	Solder bath : After immersing in flux, dip in 245 ± 5°C molten solder bath for 2 ± 0.5 seconds
Resistance to solder Heat	Satisfy electrical characteristics without distinct deformation in appearance	(1) Pre-heat : 100 ~ 110°C for 30 seconds (2) Immersed at solder bath of 270 ± 5°C for 20 ± 1 seconds
Vibration	Satisfy electrical characteristics without Mechanical damage such as break	Vibrate as apply 20 to 2,000Hz, 186m/s ² (19G) acceleration 1.5mm amplitude for 2 hours in each of three (X, Y, Z) axis (total 6 hours).
Shock	Satisfy electrical characteristics without mechanical damaged such as break	(1) Break value : 490 N (2) Duration of pulse : 11ms (3) 3 times in each positive and negative direction of 3 mutual perpendicular directions.
Bending Test	Satisfy electrical characteristics without mechanical damage such as break	Bending value : 3mm for 30 ± 1 seconds
Solvent Resistant	Marking should be legible without mechanical and distinct damage in appearance	(1) Solvent : Trichloroethane or Isopropyl alcohol. (2) Immersed in solvent at room temperature for 90 seconds
Drop Test	Satisfy electrical characteristics without mechanical damage	Drop the sample from a height of 1m to concrete ground for 10 times

8-3 Load Life

Item	Specification and Requirement	Test Method
Rapid change of temperature	Satisfy Electrical Characteristics. Without distinct damage.	Perform 5 cycles as follows : -55°C for 30minutes → room temperature for 3 minutes→ +125°C for 30minutes → room temperature for 3 minutes. (Dwell time : 5 to 8 minutes)
Humidity Resistance Test	Satisfy Electrical Characteristics. Without distinct damage.	Precondition at +25°C for 1hour. Let stand at temperature +40 ± 3°C, 90~95% relative humidity for 1,000 hours before taking final measurements.
Low Temperature Store	Satisfy Electrical Characteristics. Without distinct damage.	Solder the sample on PCB. Exposure at -55 ± 3°C for 1,000 hours. 1~2 hours exposure at room temperature and humidity, prior to measurement.
High Temperature Store	Satisfy Electrical Characteristics. Without distinct damage.	Solder the sample on PCB. Exposure at +85 ± 3°C for 1,000 hours. 1~2 hours exposure at room temperature and humidity, prior to measurement.

9. Packaging

9-1 Dimensions

9-1-1 Tape packaging dimensions

Cover Material : Polyethylene

Tape Material : Paper

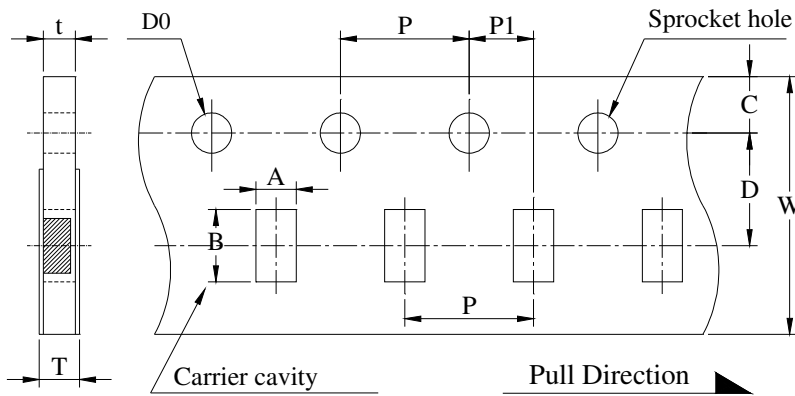

Code	Dimensions (mm)
A	1.10 ±0.10
B	1.90 ±0.10
C	1.75 ±0.1
D	3.5 ±0.05
W	8.0 ±0.3
P	4.0 ±0.1
P1	2.0 ±0.05
T	0.65 ±0.10
t	0.6 ±0.10
D0	φ 1.5 ^{+0.1} / _{-0.0}

9-1-2 Setting Direction

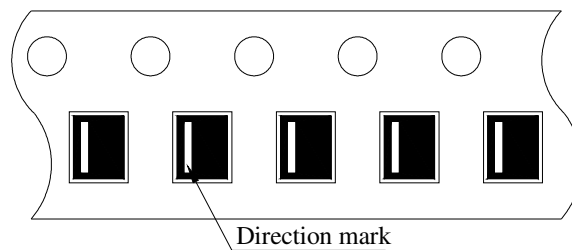

9-1-3 Reel dimensions(Material : Polystyrene)

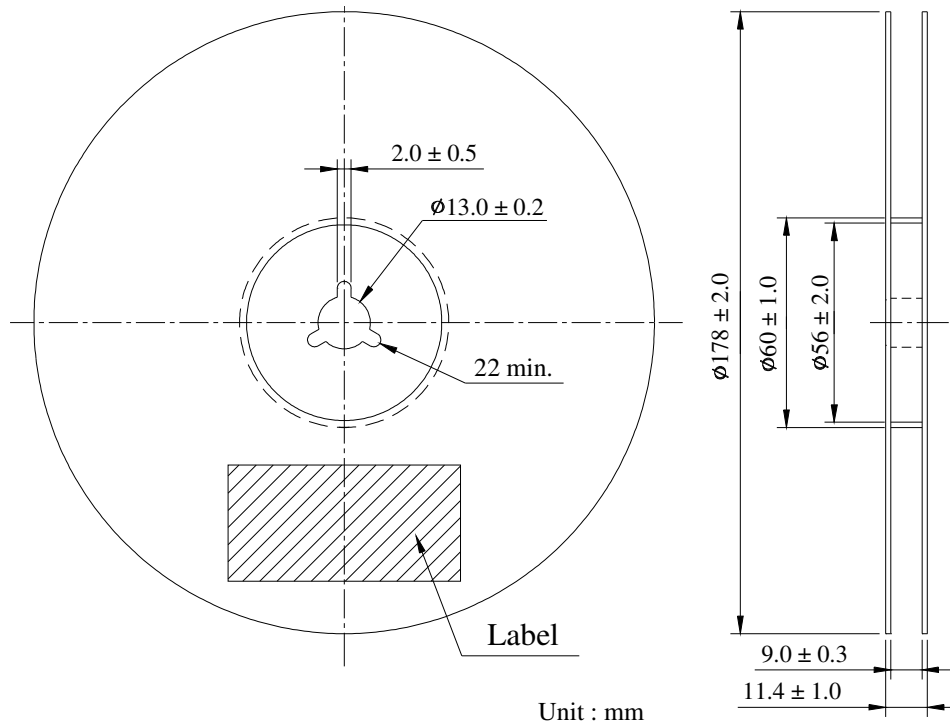

9-2 Peel force of top cover tape

The peel speed shall be about 300 mm/minute

The peel force of top cover tape shall be between 10 to 70g

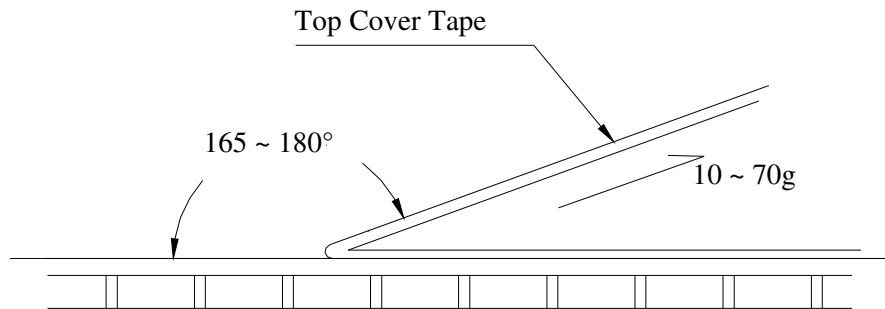

9-3 Numbers of taping

4,000 pieces/reel

9-4 Label marking

The following items shall be marked on the production and shipping Label on the reel.

9-4-1 Production Label

- (1) Part No.
- (2) Description
- (3) Quantity
- (4) Taping No.

9-4-2 Shipping Label

- (1) *Customer's name
- (2) *Customer's part No.
- (3) Manufacturer's part No.
- (4) Manufacturer's name
- (5) Manufacturer's country

*Note : Item (1) and (2) are listed by request