

TABLE 1	
PART NUMBER	"B"
SCRES-G-XX.XX-D	12.7 [0.50]
SCRES-G-XX.XX-BC	12.7 [0.50]

DESIGNED & DIMENSIONED
IN MILLIMETERS[INCHES]

SCRES-X-XX.XX-XX

PLATING SPECIFICATION

-G: .000050" GOLD ON CONTACT AREAS, NICKEL ON SHELLS

END OPTION

-D: DOUBLE ENDED (ONE END SEALED) (SEE FIG 1, SHT. 1)
-BC: BLUNT CUT (SEE FIG 2, SHT. 2)

LENGTH

-XX.XX (SEE TABLE 1) (IN METERS)
(0.17M[6.69] MIN - 50.00M[1968.50] MAX)

***NOTE:** -0.25 AND -0.50 ARE CATALOG STANDARD LENGTHS. FOR OTHER LENGTHS CONTACT SAMTEC.

THIS PRODUCT MANUFACTURED WITH LEAD-FREE PROCESSING

DO NOT SCALE FROM THIS PRINT

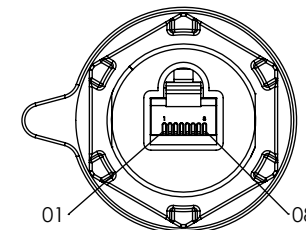
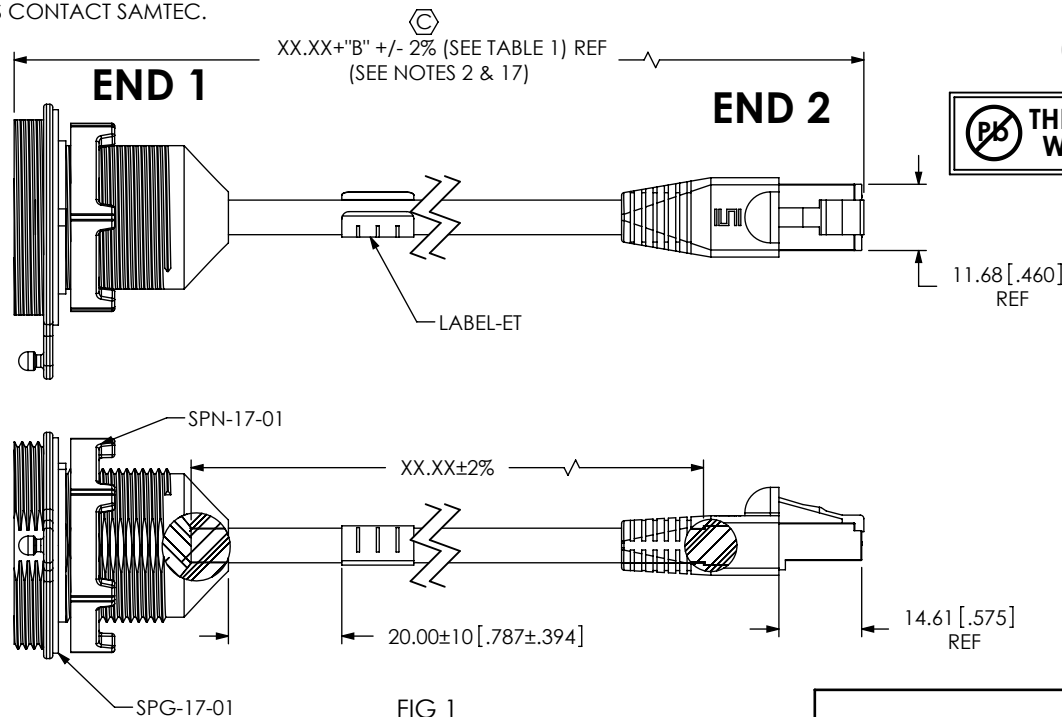
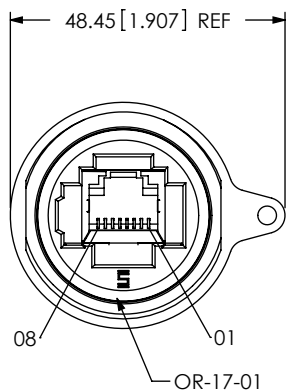
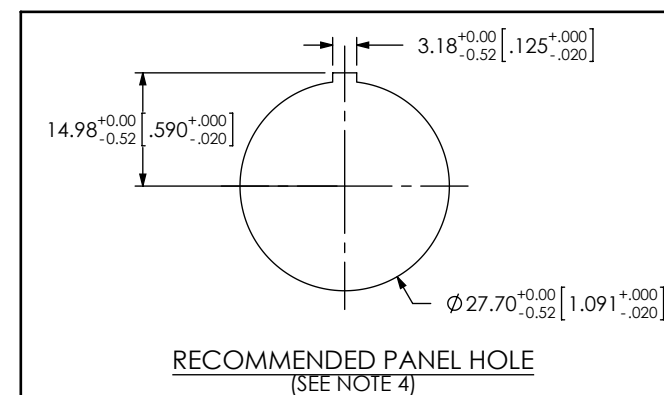

FIG 1
SCRES-G-XX.XX-D



NOTES:

1. REPRESENTS A CRITICAL DIMENSION.
2. ASSEMBLY TO BE 100% TESTED TO CAT 3 USING FLUKE DTX-1800 CABLE ANALYZER BEFORE PREMOLD AND AFTER FINISHED ASSEMBLY. AFTER FINAL ELECTRICAL TEST, LABEL WITH 1 LABEL-ET.
3. DELETE
4. PANEL THICKNESS: 0.8[.03] - 5.2[.20].
5. NOTE DELETED.
6. TORQUE SPECIFICATION FOR SPN-17-01 IS 12 IN-LB.
7. PART MUST SCREW INTO SAMTEC PART # SCN-17-01.
8. PART MUST SCREW INTO SAMTEC PART # SPN-17-01
9. FLAT REQUIRED AT PARTING LINE OF CAMS TO AVOID DRAGGING THREADS.
10. NOTE DELETED.
11. ALL IDENTIFICATION MARKS MUST NOT STAND GREATER THAN 0.051[.002] OFF THE SURFACE OF THE PART.
12. MOLD TO BE INSERTED TO ACCEPT DIFFERENT CABLE DIAMETERS.
13. ALL EJECTOR PIN AND GATE LOCATIONS MUST BE APPROVED BY SAMTEC PRODUCT ENGINEERING.
14. ANY ADDITIONAL VOIDING AND/OR MODIFICATIONS TO VOIDING MUST BE APPROVED BY SAMTEC PRODUCT ENGINEERING.
15. SAMTEC LOGO SHALL APPEAR ON SURFACE SHOWN, APPROXIMATELY 1.88 X 3.00.
16. COMPONENTS OF ASSEMBLY TO BE INSPECTED USING COMPONENT PRINTS.
17. ASSEMBLY TO BE BULK PACKAGED.
18. NOTE DELETED.

CPC FREQUENCY THIS SHEET	
A	
B	C2
C	
D	

UNLESS OTHERWISE SPECIFIED, DIMENSIONS ARE IN MILLIMETERS.
TOLERANCES ARE:
DECIMALS ANGLES
X.X: ±0.35[.014] 2°
X.XX: ±0.25[.010]
X.XXX: ±0.15[.0060]

PROPRIETARY NOTE

THIS DOCUMENT CONTAINS INFORMATION CONFIDENTIAL AND PROPRIETARY TO SAMTEC, INC. AND SHALL NOT BE REPRODUCED OR TRANSFERRED TO OTHER DOCUMENTS OR DISCLOSED TO OTHERS OR USED FOR ANY PURPOSE OTHER THAN THAT WHICH IT WAS OBTAINED WITHOUT THE EXPRESSED WRITTEN CONSENT OF SAMTEC, INC.

MATERIAL: DO NOT SCALE DRAWING

INSULATOR: GLASS FILLED THERMOPLASTIC
CONTACTS: COPPER ALLOY
SHIELDS: CR
CABLE NUT: PA66
SEALED PREMOLD: TPE (RF640A), SHOT WEIGHT: 10.66G[.024LB]
SEALED OVERMOLD: PA66 GF14 FR (80G14), SHOT WEIGHT: 12.7G[.028LB]

F:\DWG\MISC\MKTG\SCRES-X-XX.XX-XX-MKT.SLDDRW

SHEET SCALE: 1:1.5384

samtec

520 PARK EAST BLVD, NEW ALBANY, IN 47150
PHONE: 812-944-6733 FAX: 812-948-5047
e-Mail: info@SAMTEC.com code: 5332

DESCRIPTION:
SEALED CIRCULAR RECEPTACLE, ETHERNET

DWG. NO.
SCRES-X-XX.XX-XX

BY: B.HARPENAU 5/4/2007 SHEET 1 OF 6

REVISION N

END 1

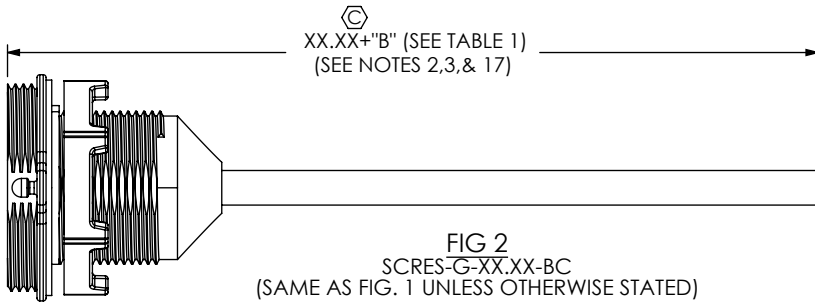

END 1

-D: IN-PROCESS 1
ECA-02-02
CUT CABLE TO LENGTH
& ADD ETHB-01

END 2

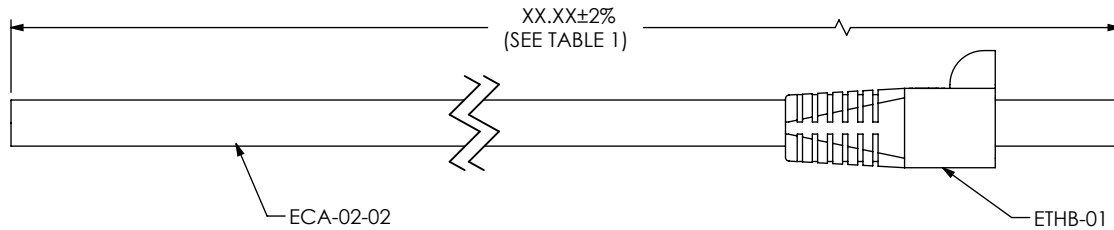

END 1

-D: IN-PROCESS 2
STRIP OUTER JACKET TO DIMENSION SHOWN

END 2

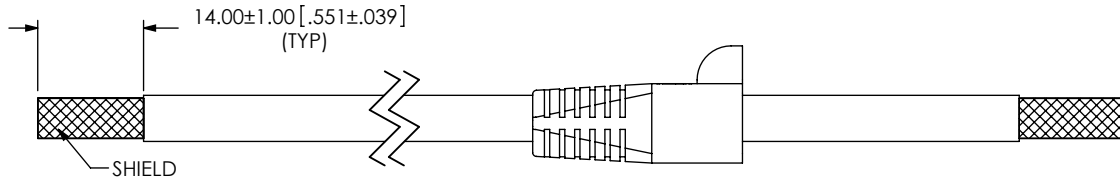

END 1

-D: IN-PROCESS 3
J1 END: TWIST SHIELD TO FORM SINGLE CONDUCTOR.
STRIP INDIVIDUAL WIRES TO DIMENSION SHOWN & TIN DIP
J2 END: FOLD BACK SHIELD

END 2

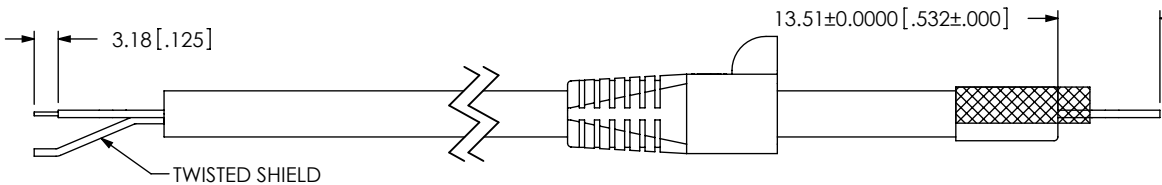

F:\DWG\MISC\MKTG\SCRES-X-XX.XX-XX-MKT.SLDDRW

CPC FREQUENCY THIS SHEET	
A	
B	C3, C4
C	
D	

PROPRIETARY NOTE
THIS DOCUMENT CONTAINS INFORMATION
CONFIDENTIAL AND PROPRIETARY TO
SAMTEC, INC. AND SHALL NOT BE REPRODUCED
OR TRANSFERRED TO OTHER DOCUMENTS OR
DISCLOSED TO OTHERS OR USED FOR ANY
PURPOSE OTHER THAN THAT WHICH IT WAS
OBTAINED WITHOUT THE EXPRESSED WRITTEN
CONSENT OF SAMTEC, INC.

DO NOT SCALE DRAWING

SHEET SCALE: 1:1

samtec

520 PARK EAST BLVD, NEW ALBANY, IN 47150
PHONE: 812-944-6733 FAX: 812-948-5047
e-Mail: info@SAMTEC.com code: 55322

DESCRIPTION:
SEALED CIRCULAR RECEPTACLE, ETHERNET

DWG. NO.
SCRES-X-XX.XX-XX

BY: B.HARPENAU 5/4/2007 SHEET 2 OF 6

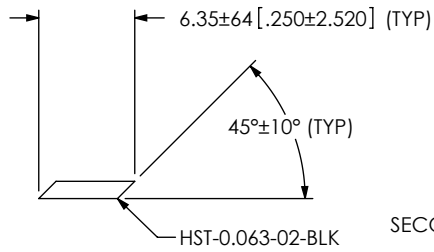

FIG 3
HST-0.063-02-BLK

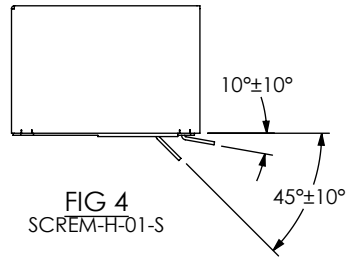
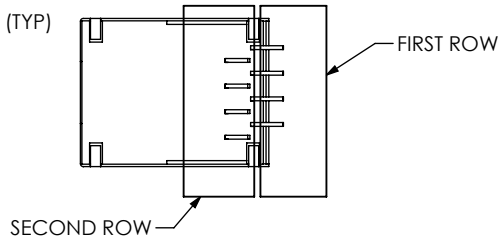
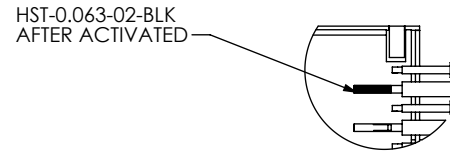

FIG 4
SCREM-H-01-S

-D: IN-PROCESS 4 J1 END
 CUT HEAT SHRINK (SEE FIG.3)
 ADD HEAT SHRINK TO INDIVIDUAL WIRES
 FORM FIRST ROW OF TAILS (SEE FIG. 4)
 TERMINATE WIRES TO FIRST ROW OF LEADS
 PUSH HEAT SHRINK TO BASE OF TAIL AND ACTIVATE
 FORM SECOND ROW OF TAILS (SEE FIG.4)
 TERMINATE WIRES TO SECOND ROW OF LEADS
 PUSH HEAT SHRINK TO BASE OF TAIL AND ACTIVATE
 SOLDER SHIELD TO SCREM-H-01-S SHIELD



DETAIL 'E'
SCALE 2 : 1

TABLE 2 - PIN-OUT	
END 1	COLOR
01	WHITE/ORANGE
02	ORANGE
03	WHITE/GREEN
04	BLUE
05	WHITE/BLUE
06	GREEN
07	WHITE/BROWN
08	BROWN
SHELL	BRAID

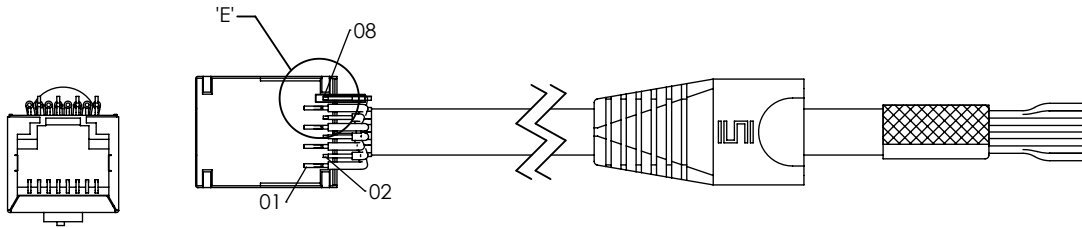

3.59 [.141] MAX
(SHIELD TO BE SOLDERED IN THIS AREA)

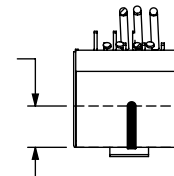

SECTION "F"-"F"

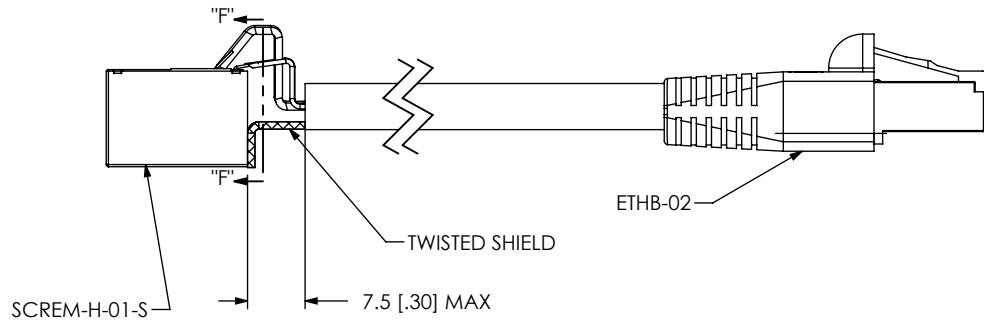

SCREM-H-01-S 7.5 [.30] MAX

F:\DWG\MISC\MKTG\SCRES-X-XX.XX-MKT.SLDDRW

CPC FREQUENCY THIS SHEET
A
B
C
D

PROPRIETARY NOTE
 THIS DOCUMENT CONTAINS INFORMATION CONFIDENTIAL AND PROPRIETARY TO SAMTEC, INC. AND SHALL NOT BE REPRODUCED OR TRANSFERRED TO OTHER DOCUMENTS OR DISCLOSED TO OTHERS OR USED FOR ANY PURPOSE OTHER THAN THAT WHICH IT WAS OBTAINED WITHOUT THE EXPRESSED WRITTEN CONSENT OF SAMTEC, INC.

DO NOT SCALE DRAWING

SHEET SCALE: 1:1



520 PARK EAST BLVD, NEW ALBANY, IN 47150
 PHONE: 812-944-6733 FAX: 812-948-5047
 e-Mail: info@SAMTEC.com code: 55322

DESCRIPTION:
 SEALED CIRCULAR RECEPTACLE, ETHERNET

DWG. NO. SCRES-X-XX.XX-XX

BY: B.HARPENAU/4/2007

SHEET 3 OF 6

TABLE 3 - PIN-OUT		
END 1	COLOR	END 2
01	WHITE/ORANGE	01
02	ORANGE	02
03	WHITE/GREEN	03
04	BLUE	04
05	WHITE/BLUE	05
06	GREEN	06
07	WHITE/BROWN	07
08	BROWN	08 </td
SHELL	BRAID	SHELL

-D: IN-PROCESS 5
 TERMINATE J2 TO MODP-01-8P8C-X-XX AND SLIDE
 ETHB-02 ONTO MODP-01-8P8C-X-XX
 (SEE NOTE 2)

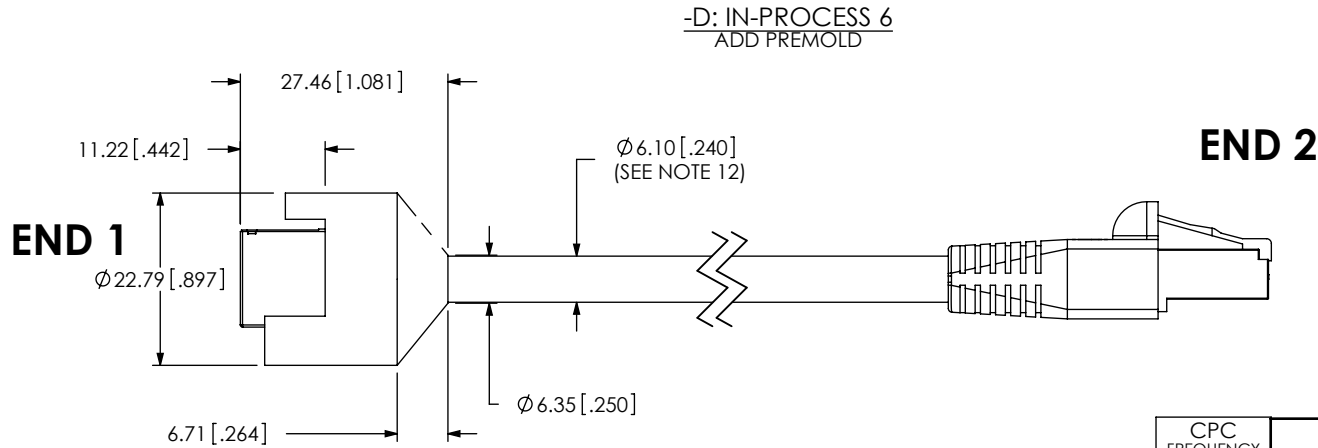
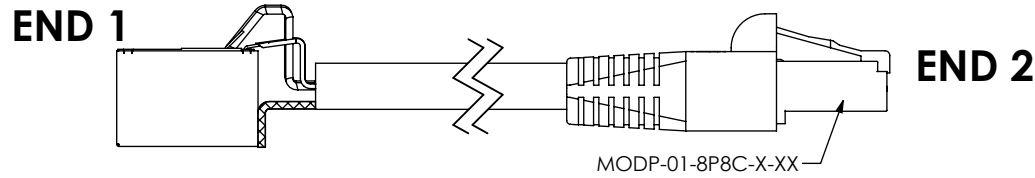

F:\DWG\MISC\MKTG\SCRES-X-XX-XX-MKT.SLDDRW

CPC FREQUENCY THIS SHEET
A
B
C
D

PROPRIETARY NOTE
 THIS DOCUMENT CONTAINS INFORMATION
 CONFIDENTIAL AND PROPRIETARY TO
 SAMTEC, INC. AND SHALL NOT BE REPRODUCED
 OR TRANSFERRED TO OTHER DOCUMENTS OR
 DISCLOSED TO OTHERS OR USED FOR ANY
 PURPOSE OTHER THAN THAT WHICH IT WAS
 OBTAINED WITHOUT THE EXPRESSED WRITTEN
 CONSENT OF SAMTEC, INC.

DO NOT SCALE DRAWING

SHEET SCALE: 1:1



520 PARK EAST BLVD, NEW ALBANY, IN 47150
 PHONE: 812-944-6733 FAX: 812-948-5047
 e-Mail: info@SAMTEC.com code: 55322

DESCRIPTION:
 SEALED CIRCULAR RECEPTACLE, ETHERNET

DWG. NO. **SCRES-X-XX.XX-XX**

BY: B.HARPENAU 5/4/2007 SHEET 4 OF 6

-D: IN-PROCESS 8
 ADD OVER MOLD, OR-17-01,
 SPG-17-01, AND SPN-17-01
 (SEE NOTE 2)

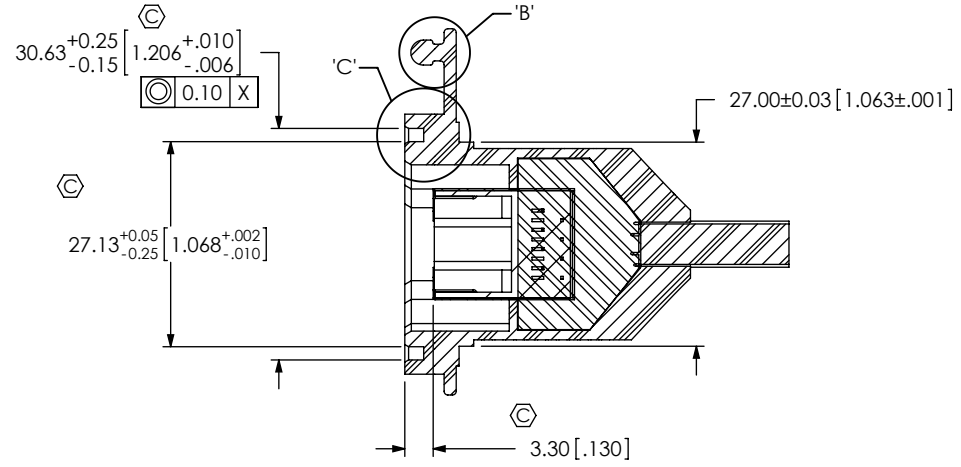
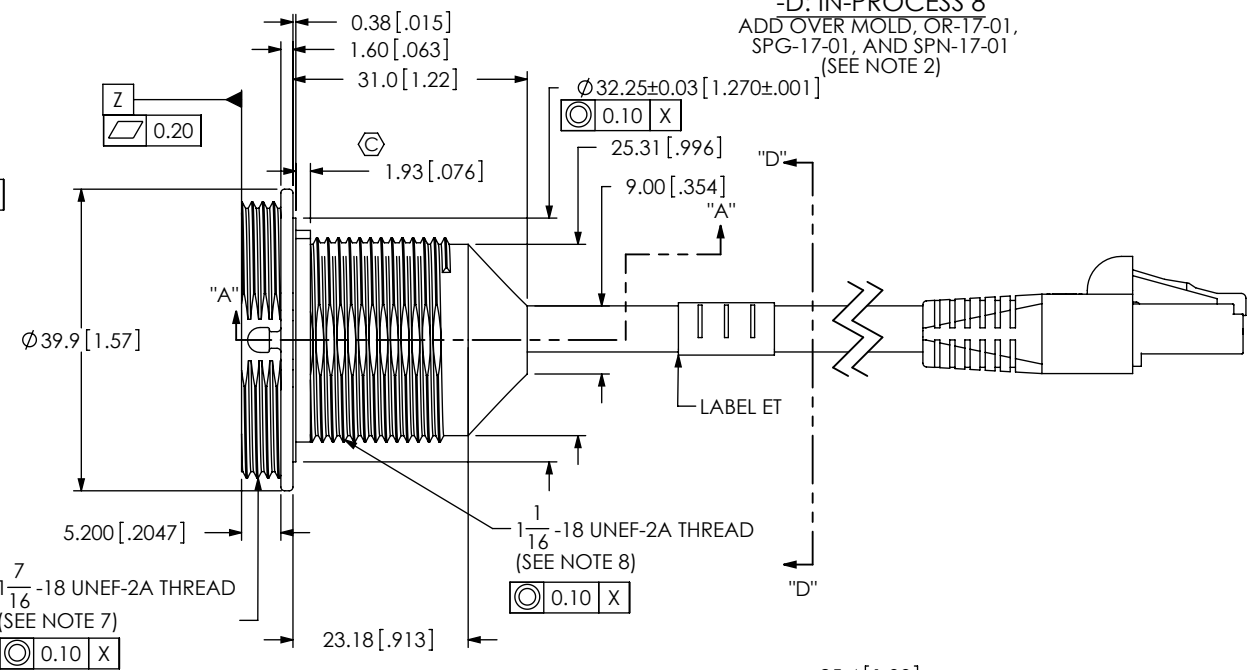
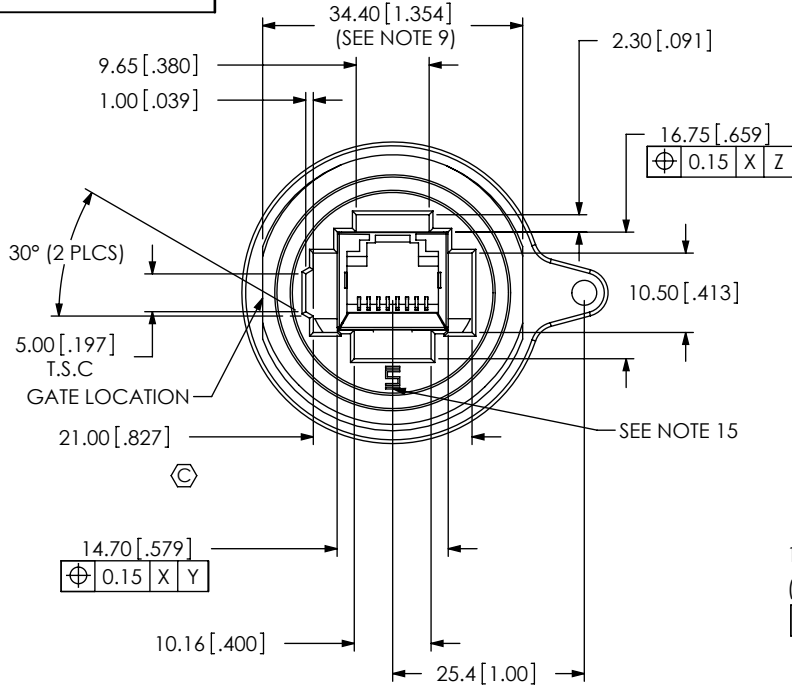

SECTION "A"-"A"

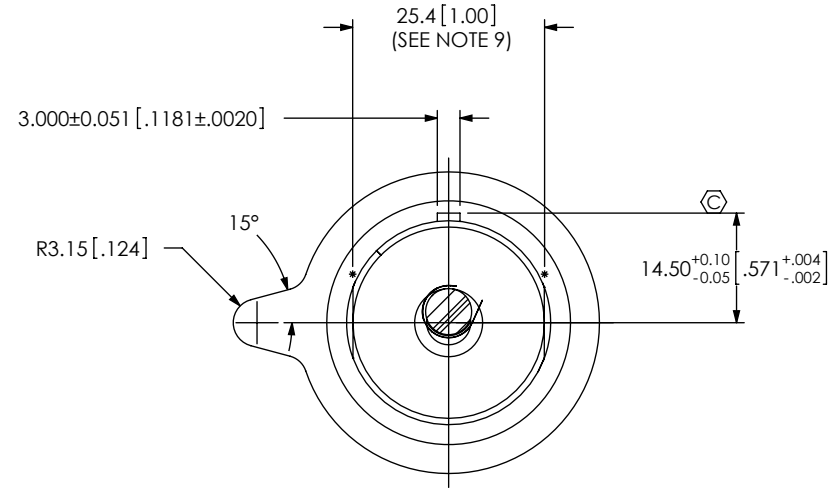

SECTION "D"-"D"

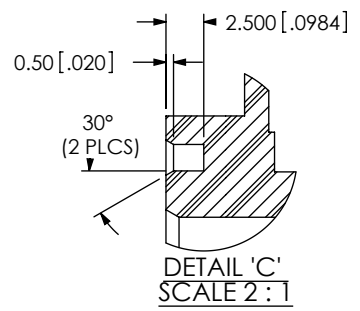
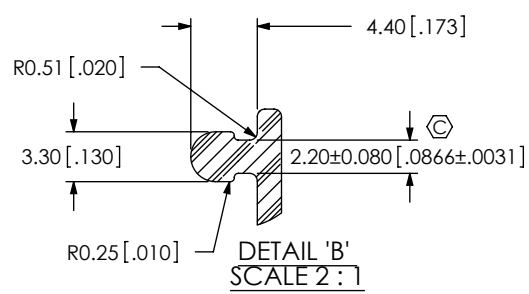

CPC FREQUENCY THIS SHEET
A, C6, C7, C12
B
C
D

PROPRIETARY NOTE
 THIS DOCUMENT CONTAINS INFORMATION CONFIDENTIAL AND PROPRIETARY TO SAMTEC, INC. AND SHALL NOT BE REPRODUCED OR TRANSFERRED TO OTHER DOCUMENTS OR DISCLOSED TO OTHERS OR USED FOR ANY PURPOSE OTHER THAN THAT WHICH IT WAS OBTAINED WITHOUT THE EXPRESSED WRITTEN CONSENT OF SAMTEC, INC.

DO NOT SCALE DRAWING

SHEET SCALE: 1:1

F:\DWG\MISC\MKTG\SCRES-X-XX.XX-XX-MKT.SLDDRW

520 PARK EAST BLVD, NEW ALBANY, IN 47150
 PHONE: 812-944-6733 FAX: 812-948-5047
 e-Mail: info@SAMTEC.com code: 55322

DESCRIPTION:
 SEALED CIRCULAR RECEPTACLE, ETHERNET

DWG. NO. SCRES-X-XX.XX-XX

BY: B.HARPENAU 5/4/2007 SHEET 5 OF 6

REVISION N

-BC IN-PROCESS 1
ECA-02-XX
CUT CABLES TO LENGTH

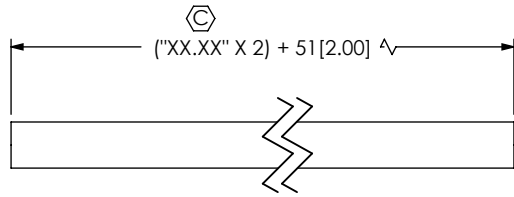

-BC: IN-PROCESS 5
(SAME AS -D IN-PROCESS 7 UNLESS OTHERWISE STATED)

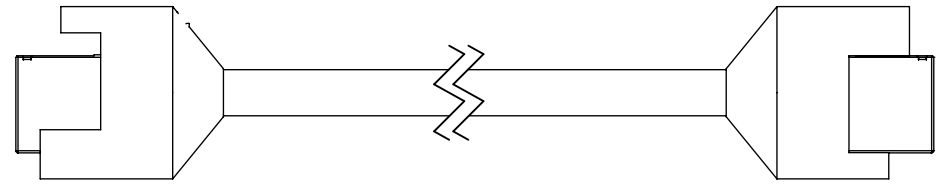

-BC: IN-PROCESS 2
(SAME AS -D UNLESS OTHERWISE STATED)

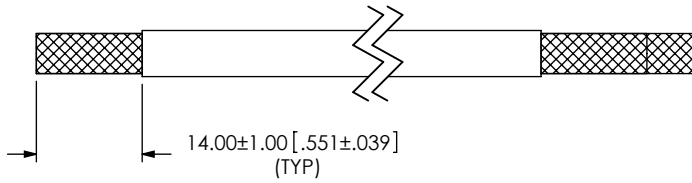

-BC: IN-PROCESS 6
(SAME AS -D IN-PROCESS 8 UNLESS OTHERWISE STATED)
(SEE NOTE 2)

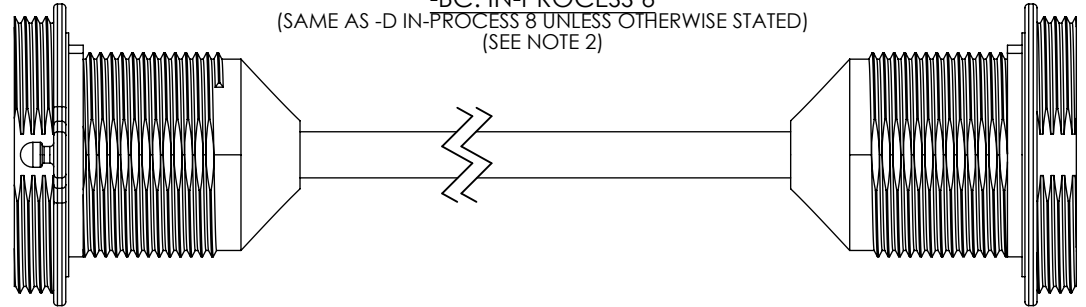

-BC: IN-PROCESS 3
(SAME AS -D UNLESS OTHERWISE STATED)

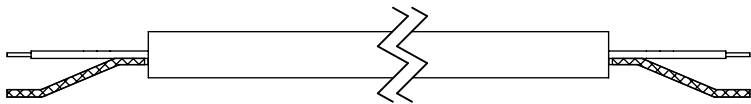

-BC: IN-PROCESS 7
CUT IN HALF & TRIM TO LENGTH
ADD OR-17-01, SPG-17-01, & SPN-17-01

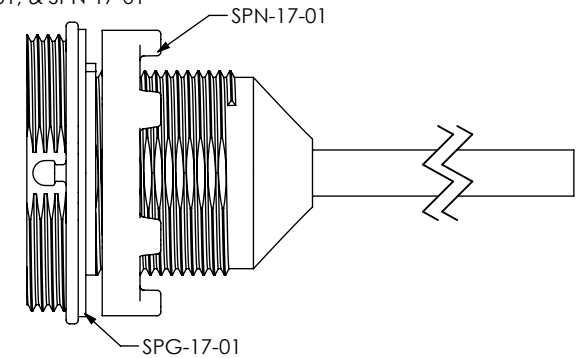
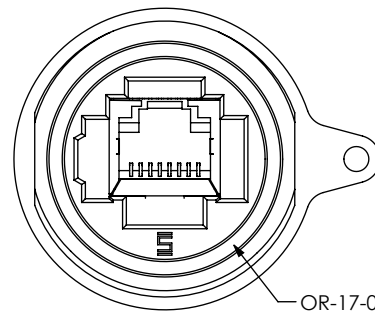

-BC: IN-PROCESS 4
(SAME AS -D UNLESS OTHERWISE STATED)

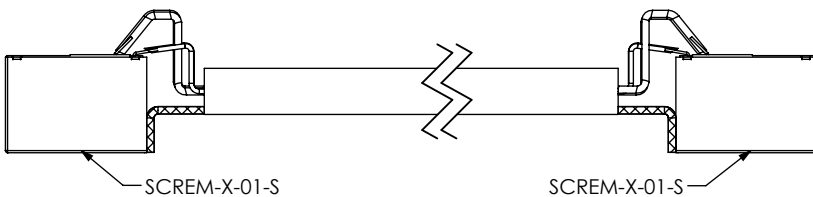

F:\DWG\MISC\MKTG\SCRES-X-XX.XX-MKT.SLDDRW

CPC FREQUENCY THIS SHEET	
A	
B	
C	
D	

PROPRIETARY NOTE
THIS DOCUMENT CONTAINS INFORMATION CONFIDENTIAL AND PROPRIETARY TO SAMTEC, INC. AND SHALL NOT BE REPRODUCED OR TRANSFERRED TO OTHER DOCUMENTS OR DISCLOSED TO OTHERS OR USED FOR ANY PURPOSE OTHER THAN THAT WHICH IT WAS OBTAINED WITHOUT THE EXPRESSED WRITTEN CONSENT OF SAMTEC, INC.

DO NOT SCALE DRAWING

SHEET SCALE: 1:1

samtec

520 PARK EAST BLVD, NEW ALBANY, IN 47150
PHONE: 812-944-6733 FAX: 812-948-5047
e-Mail: info@SAMTEC.com code: 55322

DESCRIPTION:
SEALED CIRCULAR RECEPTACLE, ETHERNET

DWG. NO. **SCRES-X-XX.XX-XX**

BY: B.HARPENAU 5/4/2007 SHEET 6 OF 6